

Build an Anemometer

Levels



Grades K-4

Overview:

During this project, students build a model anemometer. The model anemometers will be used to measure wind speed in another lesson.

Objectives:

The student will build an anemometer to measure wind speed (level II).

GLEs Addressed:

Science

- [3-4] SA1.1 The student demonstrates an understanding of the processes of science by asking questions, predicting, observing, describing, measuring, classifying, making generalizations, inferring, and communicating.
- [3] SE2.1 The student demonstrates an understanding that solving problems involves different ways of thinking, perspectives, and curiosity by identifying local tools and materials used in everyday life.
- [4] SE2.1 The student demonstrates an understanding that solving problems involves different ways of thinking, perspectives, and curiosity by identifying the function of a variety of tools (e.g., spear, hammer, hand lens, kayak, computer).

Whole Picture:

An anemometer measures the force or speed of the wind. A common anemometer, such as the one constructed in this lesson, uses cups mounted on four horizontal arms at equal distance from each other on a vertical shaft. The air flow past the cups turns the cups in proportion to the speed of the wind.

There are several other kinds of anemometers that serve to measure wind variables. For example:

- A windmill, or propeller, anemometer is generally coupled with a wind vane to measure speed and direction simultaneously.
- A sonic anemometer uses ultrasonic waves to measure wind speed and direction.
- A pressure anemometer gauges the force of the wind by the amount of pressure it exerts on the surface of a plate. Such devices do not measure light winds accurately but are effective in heavy wind.

Many anemometers convert the revolutions per minute into wind speed measured in several different ways:

MPH (miles per hour) – unit of speed measuring the number of miles covered in a period of one hour.

Knots – unit of speed measuring one nautical mile per hour.

M/S (meters per second) – unit of speed measuring the number of meters covered in one second.

F/S (feet per second) – unit of speed that tells the number of feet covered in one second.

KM/H (kilometers per hour) – unit of speed that tells the number of kilometers covered in one hour.

Wind speed is an important thing to know for many professions. Information obtained from an anemometer is vital for weather forecasters, pilots, sailors and builders – to name a few. A crane operator, for example, needs to know wind speed and direction when there are plans to operate a tall crane. Even a landfill must know the behavior of the wind in order to maintain odor control.

Materials:

- STUDENT INSTRUCTION SHEETS: “Build a Anemometer”
- Flexible straws (4 per student)
- Condiment cups (4 per student)
- Balsa wood or mat board, very thin, cut to 1-1/2” square (2 per student)
- Pencils with flat erasers (1 per student)
- Washers (1 per student)
- T-pins, large (1 per student)
- Smiley-face stickers (1 per student)

Activity Preparation:

Before teaching this lesson, build a demonstration model to show the class. Locate a place for students to store their models until it is time to use them again in the “Measuring Wind Speed” lesson.

Activity Procedure:

1. Explain to students that today they will build a model anemometer. An anemometer is an instrument that measures how fast the wind is blowing.
2. Distribute the Student Instruction Sheet: “Build an Anemometer” and the following materials to each student: 4 flexible straws, 4 condiment cups, 2 balsa wood or mat board squares, 1 pencil with eraser, 1 washer, 1 T-pin, 1 sticker.
3. Using the Student Instruction Sheet : “Build an Anemometer” as a guide, lead students through the process of building their anemometers. Allow students to complete each step before moving on. (See Teacher Note, above.)
4. If there is enough time, take the class outside to use their models. Explain they will use their models in another lesson to collect information. Help students store the model anemometers in a safe place.

Vocabulary

anemometer - an instrument (or tool) used to measure the speed of the wind

instrument - a device used for doing a certain kind of work; tool

measure - to determine the size, weight, or amount of something

Teacher Note: To use this lesson with Level I students, build the anemometer while students watch. Explain each step of the process. Allow each student to examine and use the instrument when it is completed.

Build an Anemometer

Student Instruction Sheet (page 1 of 2)

Levels



You will need:

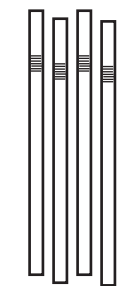

4 Straws



4 Cups



Tape



Sticker



Pin



Washer



2 Wood squares

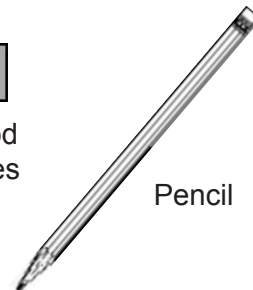

Pencil

Make an Anemometer:

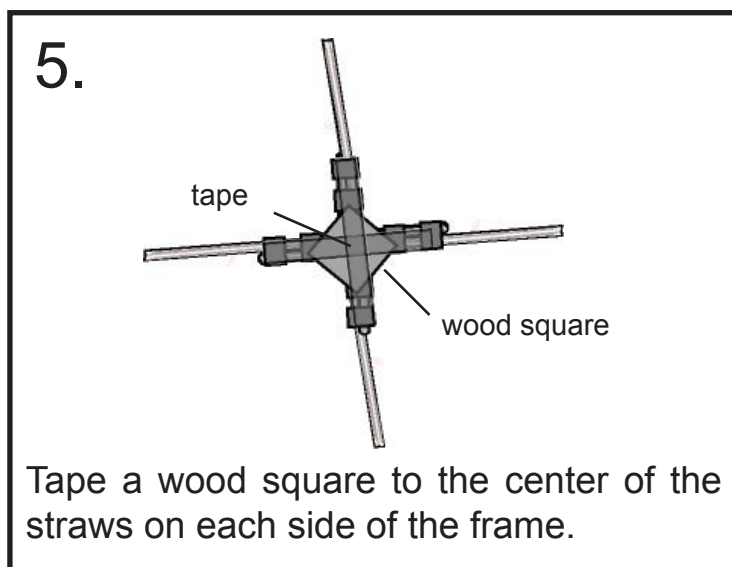
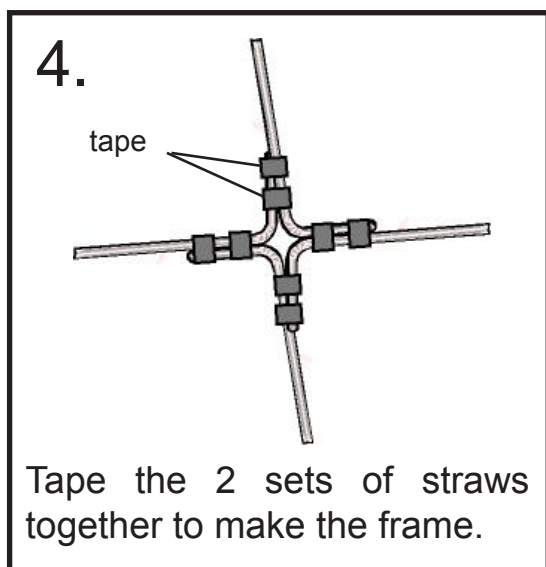
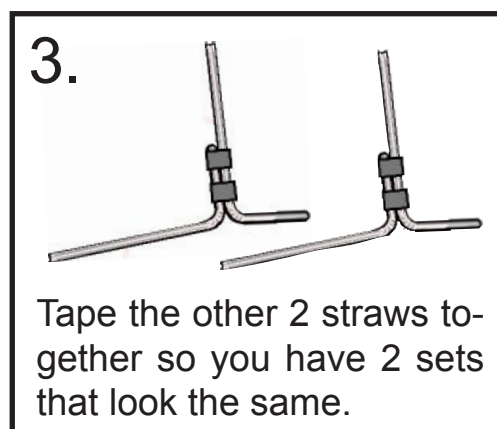
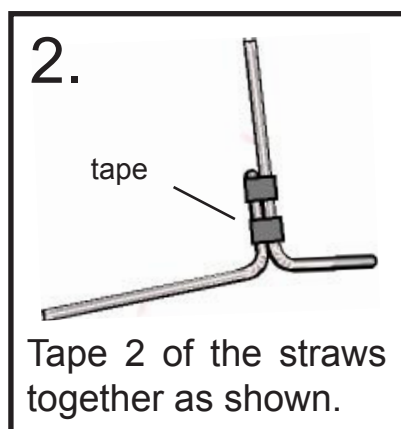
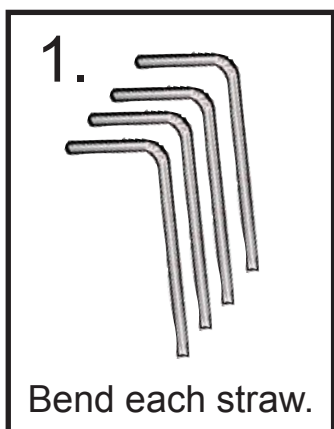

Build an Anemometer

Student Instruction Sheet (page 1 of 2)

6.

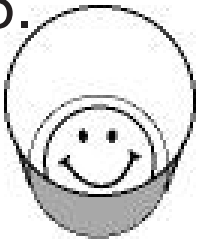

Put a sticker in the bottom of 1 cup.

7.

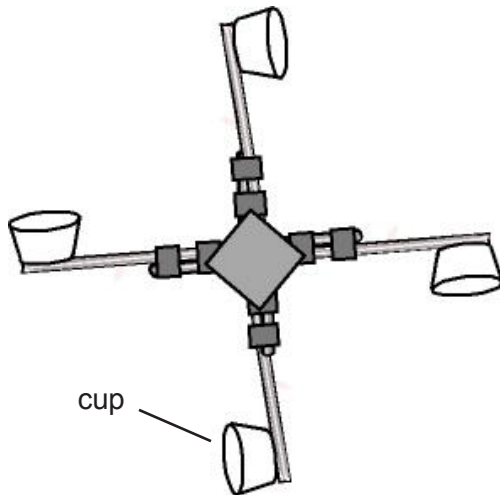

cup

Attach 1 cup to the end of each straw. Make sure each cup is pointing the right direction!

8.

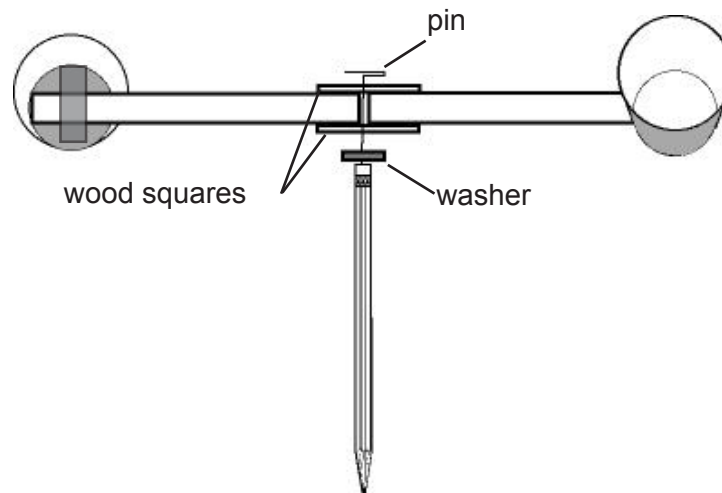

pin

wood squares

washer

Poke the pin through the wood squares in the center of the frame. Put the end of the pin through the washer, then push the pin into the pencil eraser.